

### GT2 3MM PITCH PULLEY

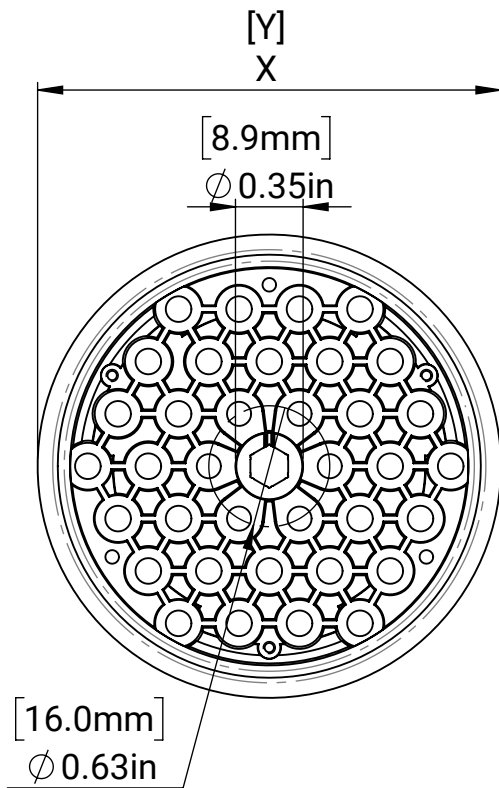

### GT2 3MM PITCH PULLEY INSERT

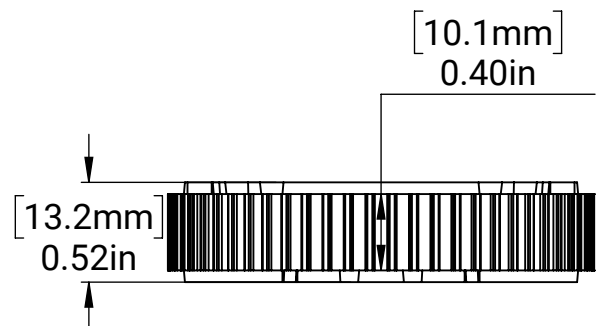
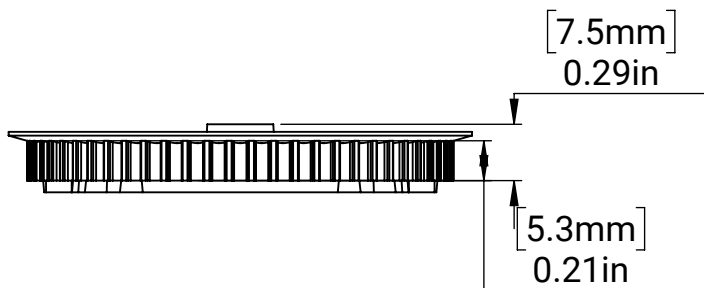
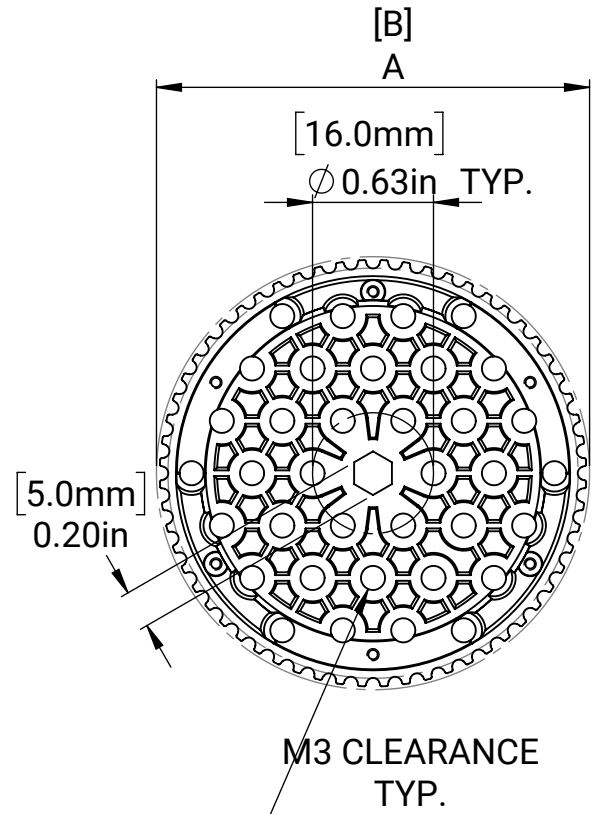

**MM SHEET TOLERANCES:**

X ± 0.50 MM  
X.X ± 0.10 MM  
X.XX ± 0.05 MM  
ANGLES ± 2°

**INCH SHEET TOLERANCES:**

X ± 0.1 IN  
X.X ± 0.02 IN  
X.XX ± 0.004 IN  
X.XXX ± 0.002 IN  
ANGLES ± 2°

**MATERIAL:**  
**ACETAL**

DATE: 7/31/2020

GT2 3MM PITCH PULLEYS & INSERTS

PRODUCT PACK PART NUMBER	INDIVIDUAL PART NUMBER	TEETH	FLANGE O.D. X (IN)	FLANGE O.D. Y (MM)	PITCH DIAMETER A (IN)	PITCH DIAMETER B (MM)
REV-45-1823	REV-41-1669 & REV-41-1670	24	1.06	26.9	.90	22.9
REV-45-1824	REV-41-1671 & REV-41-1672	30	1.29	32.6	1.13	28.7
REV-45-1825	REV-41-1673 & REV-41-1674	36	1.51	38.4	1.35	34.4
REV-45-1826	REV-41-1675 & REV-41-1676	48	1.96	49.8	1.81	45.8
REV-45-1827	REV-45-1677 & REV-45-1678	60	2.41	61.3	2.26	55.4

MM SHEET TOLERANCES:  
 X ± 0.50 MM  
 X.X ± 0.10 MM  
 X.XX ± 0.05 MM  
 ANGLES ± 2°

INCH SHEET TOLERANCES:  
 X ± 0.1 IN  
 X.X ± 0.02 IN  
 X.XX ± 0.004 IN  
 X.XXX ± 0.002 IN  
 ANGLES ± 2°

MATERIAL:  
**POM**

DATE: 7/31/2020