

ULTRAPLANETARY OUTSIDE MOUNTING BRACKET

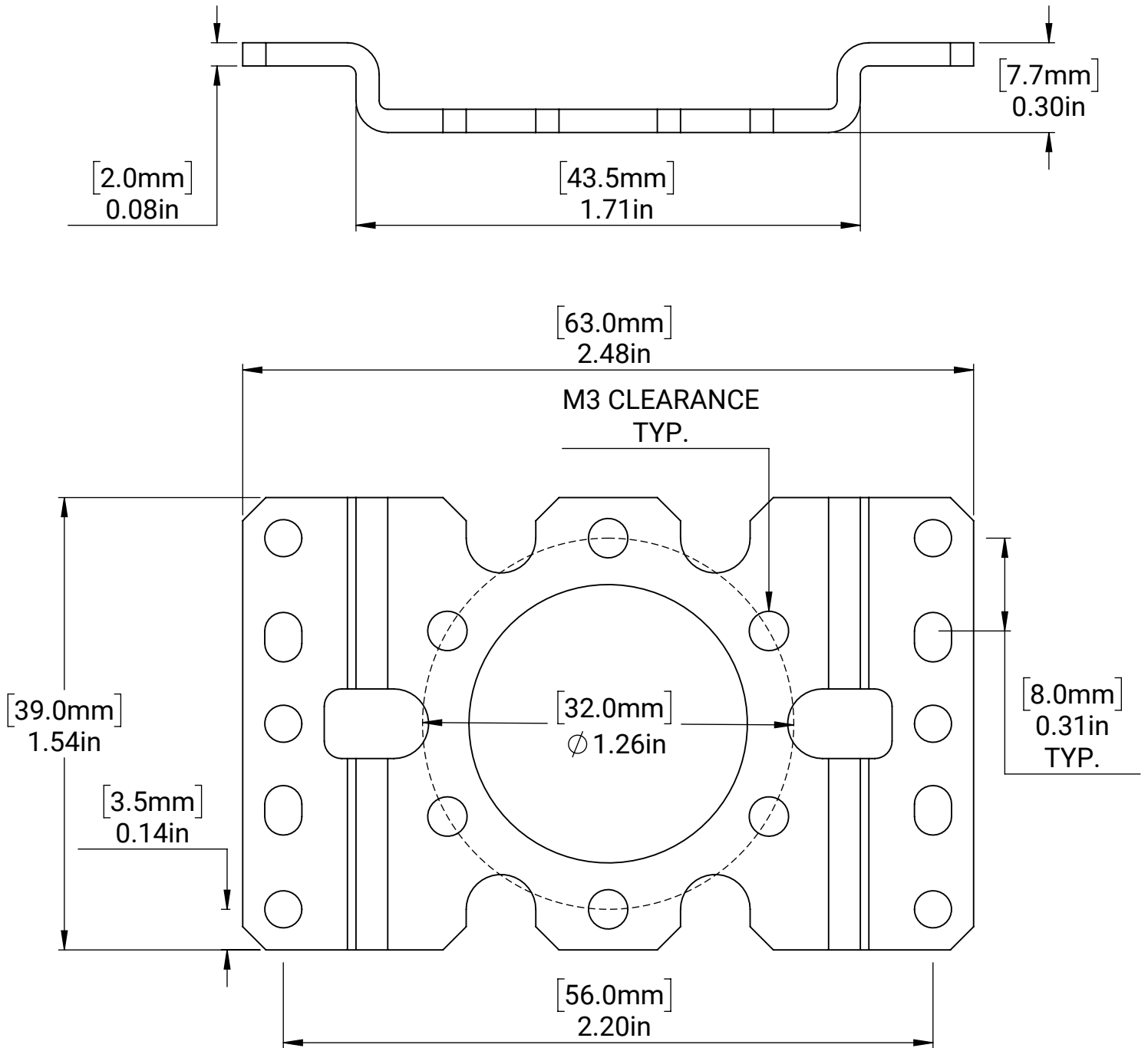

MM SHEET TOLERANCES:

X ± 0.50 MM
 X.X ± 0.10 MM
 X.XX ± 0.05 MM
 ANGLES ± 2°

INCH SHEET TOLERANCES:

X ± 0.1 IN
 X.X ± 0.02 IN
 X.XX ± 0.004 IN
 X.XXX ± 0.002 IN
 ANGLES ± 2°

MATERIAL:

5052 ALUMINUM

DATE: 7/31/2020